



18" Vertical Hauler no Shroud



24" Vertical Hauler with Shroud

- Large diameter sheaves for maximum grip and knot handling.
- Vertical sheave for ease in coiling and high speed buoyline hauling.
- Round faired design for fewer hook hang-ups.
- Adjustable tailing idler and line splitter positions.
- Rugged Galvanized construction.
- Optional shroud available for use with longer gangions - show above on 24" Hauler

Vertical Hauler with 18" Sheaves

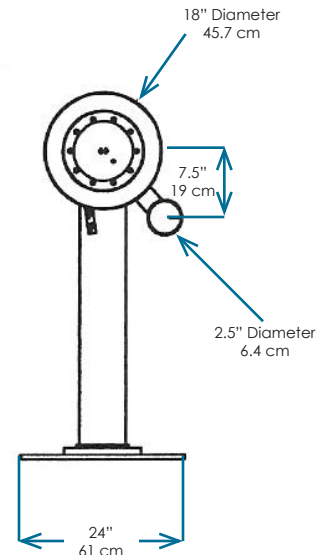
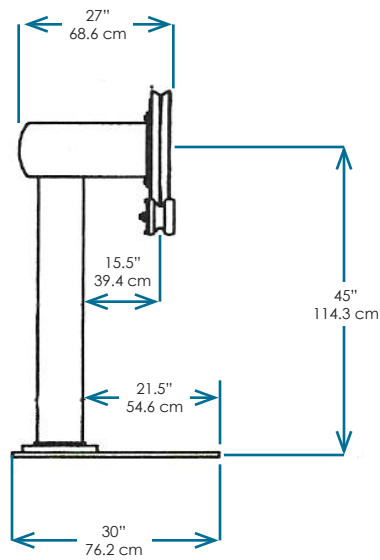

Specifications:

Weight	475 Lbs	215.9 Kgs.
Hydraulic Flow Required	16 - 20 GPM at 2000 PSI	

Vertical Hauler with 24" Sheaves

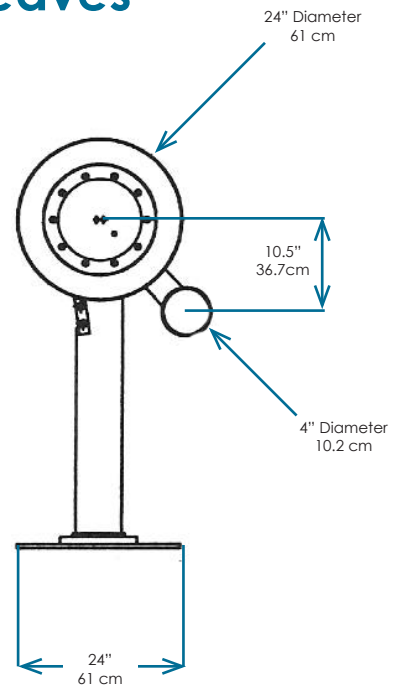
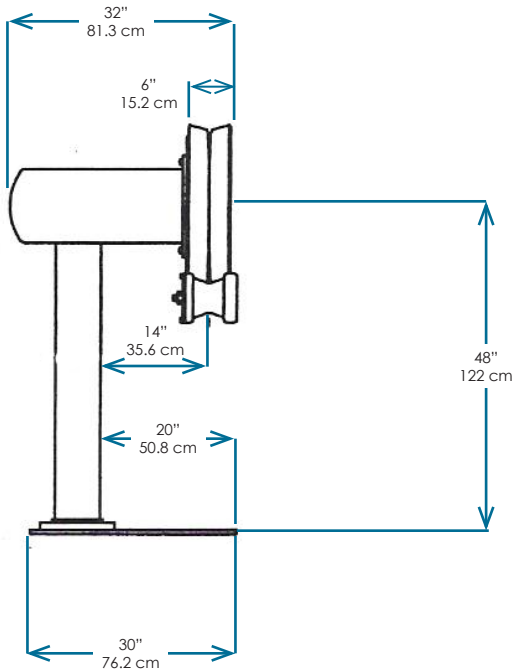

Specifications:

Weight	650 Lbs	295.5 Kgs.
Hydraulic Flow Required	20 GPM at 2000 PSI	

4259 22nd Ave. W. Seattle, WA 98199
 Phone: (206) 285-3200 Fax: (206) 282-8520
sales@marcoglobal.com
www.marcoglobal.com